

Charging of the impedance-probe by the auroral energetic electrons

Yuzo Watanabe

Institute of Space and Astronautical Science, Sagamihara 229-8510

Abstract: Three antarctic rockets S-310JA-3, 5 and 6 were launched at Syowa Station into the auroral ionosphere. Charging of the electrode caused by the energetic electrons precipitated from the magnetosphere was observed in the frequency spectra of the impedance-probe. The measurement of the probe capacitance shows that the ion sheath thickness around the probe increases with enhanced energetic electron flux.

1. Instrument

Impedance-probe was developed to measure the ionospheric electron density by using rockets and satellites in 1965 (Oya, 1965; Oya and Obayashi, 1966).

Figure 1 shows a principle of the impedance-probe. The cylindrical electrode with a length of 1 m is used as a sensor of the impedance-probe which is extended from the sensor holder by pyro technics. The sensor is connected to the condenser-bridge in the pre-amplifier. RF swept signal of the amplitude of $0.1 V_{RMS}$ is supplied to the bridge.

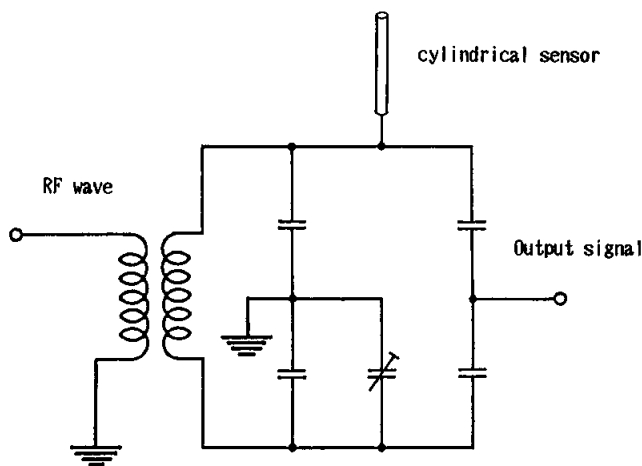

Fig. 1. Electronics circuit of the condenser-bridge of the impedance-probe. The cylindrical probe with a length of 1.0 m is used as a sensor of the impedance-probe which is connected to the condenser-bridge in the pre-amplifier. This is extended from the rocket to the outer space. Trimming condenser is adjusted to cancel stray capacitance around the probe. The balanced condition of the bridge-circuit is obtained.

Stray capacitance around the probe is cancelled by adjusting a trimming condenser of the condenser-bridge. The probe is connected to the bridge-circuit as one element of the four condensers as is shown in Fig. 1. The capacitance of the probe immersed in the plasma is measured as an imbalance of the bridge.

Impedance characteristics of the cylindrical probe is measured in the space plasma in the frequency range of 0.4 MHz to about 10 MHz. The impedance characteristics show various resonances such as upper hybrid resonance, sheath resonance, plasma resonance and modified plasma resonance (Watanabe, 1996, 1998).

The probe is electrically insulated from the rocket body through the condenser-bridge. Generally the probe potential is slightly negative with respect to the space potential (or the plasma potential). This slightly negative potential producing an ion sheath is called "floating potential". The capacitance of the sheath at the floating potential is measured at a frequency of 0.4 MHz. The sheath thickness can be obtained from the sheath capacitance at this frequency using the radius and length of the cylindrical probe. It is noted that the sheath thickness determined by this RF probe method might be thinner than the sheath thickness estimated by the DC probe, because RF probe observes the quasi-neutral region located at the outer boundary of the sheath as non-disturbed ambient plasma region, while the DC probe observes this quasi-neutral pre-sheath region as the sheath region. The sheath thickness observed by the DC probe is several times the local Debye length, λ_D , while the sheath thickness observed by the RF probe is about a half of λ_D . When the energetic electron flux from the magnetosphere enhances and these auroral electrons hit the probe surface, the probe potential negatively falls and then the ion sheath region expands.

2. Aurora rocket experiments

S-310JA-3, 5 and 6 rockets were launched at Syowa Station into the auroral ionosphere, at 1835 LT (45° EMT) on July 26, 1977, at 0156 LT on June 11, 1978 and at 0056 LT on August 28, 1978, respectively. The height profiles of the electron density obtained with these rockets are shown in Fig. 2 (Takahashi and Oya, 1979). Geomagnetic activity index, K_p , was 1+, 6 and 5 during these flights.

Electron density profiles were strongly affected by energetic electrons precipitating from the magnetosphere. Energetic electron fluxes were measured simultaneously with the same rockets (Matsumoto and Kaya, 1980). All sky camera was operated on the ground (Hirasawa, 1980). The observations by S-310JA-5 and 6 rockets are summarized respectively in Figs. 3a and 3b. In these figures, abscissa is flight time (s) after launching, or height (km) of the rocket. The upper panel shows electron density (cm^{-3}) and the lower panel energetic electron flux ($/\text{cm}^2 \cdot \text{str} \cdot \text{s} \cdot \text{keV}$). The Aurora-diagram (a meridian-time plot of aurora intensity with contour lines in kR) was obtained from a meridian-scan photometer at 557.7 nm. A series of arrows denote flight trajectory of the rocket projected along the geomagnetic field line to an altitude level of 100 km.

Figure 4a shows C_s (sheath capacitance)- f_p (plasma frequency) diagram for five values of sheath thickness normalized by λ_D ($S/\lambda_D = 0.5, 1, 1.5, 2$ and 3) for S-310JA-3, 5 and 6 rockets. These theoretical C_s - f_p curves are calculated for a cylindrical sensor of 5 mm in radius and 1 m in length, assuming that the electron temperature is 2000 K.

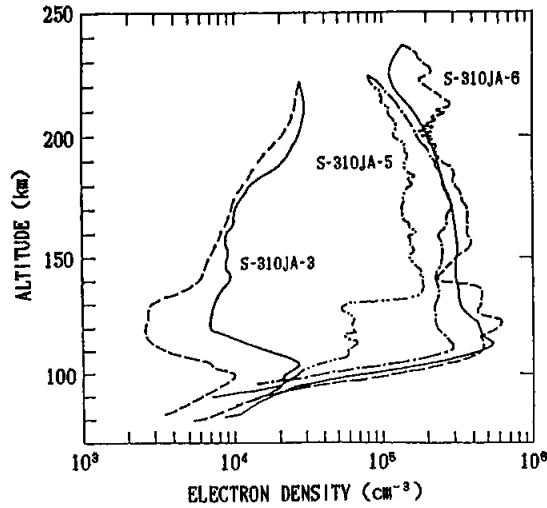

Fig. 2. Three electron density profiles observed by the antarctic rockets, S-310JA-3, 5, and 6 (provided by T. Takahashi). These rockets were launched at 1535 UT on July 26, 1977, at 2256 UT on June 10, 1978 and at 2156 UT on August 27, 1978, respectively. Electron density observed by the S-310JA-3 (—, ascent; ----, descent) are lower than that of S-310JA-5 (—, ascent; ----, descent) and that of S-310JA-6 (—, ascent; ----, descent) (Takahashi and Oya, 1979). K_p indices were 1⁺, 6 and 5 during the flights of the S-310JA-3, 5 and 6.

Large dots (●) denote observed values obtained by S-310JA-3. Cross marks (×) denote those observed by S-310JA-6 during the ascent and circles (○) during the descent of the flight. Plus marks (+) denote those observed by S-310JA-5 in the *E* region during the ascent, and small dots (·) during the flight time of 136 s to 335 s.

S/λ_D was 0.5 during the flight of S-310JA-3 rocket. This small value is understood from the fact that the electron density was lower and geomagnetic condition was calm at the time of S-310JA-3 launching.

S/λ_D value by S-310JA-6 rocket changed from 1.3 to 1.6 during ascent and descent of the flight as shown in Fig. 4a. The auroral intensity changed from 4 kR to 6 kR during this rocket flight as shown in Fig. 3b. The time variations in these two data agreed well each other. The change of the energetic electrons was also in good agreement with the change of S/λ_D and the auroral intensity.

The auroral intensity on the aurora-diagram changed from 2 kR to 5 kR from 90 s to 335 s of S-310JA-5 flight as shown in Fig. 3a. Similarly S/λ_D representing the bias effect of the probe changed from 1 to 1.5 in Fig. 4a. S/λ_D value of 1 was obtained in the *E*-region of low electron density, while 1.5 was obtained in the intense auroral region.

The C_S-f_p diagram during the descent of S-310JA-5 flight is shown in Fig. 4b. Data points from the apex of the flight to 335 s were shown in Fig. 4a because the value of S/λ_D was constant at 1.5 in the intense aurora region. S/λ_D changed from 1.5 to 1.3 and then 1 in Fig. 4b, and these values were obtained in the intense auroral region, middle of the descending path, and the *E*-region ionosphere, respectively. This time variation in S/λ_D correlates well with the auroral intensity variation from 5 kR to 3 kR and then to 2 kR in the aurora-diagram as shown in Fig. 3a.

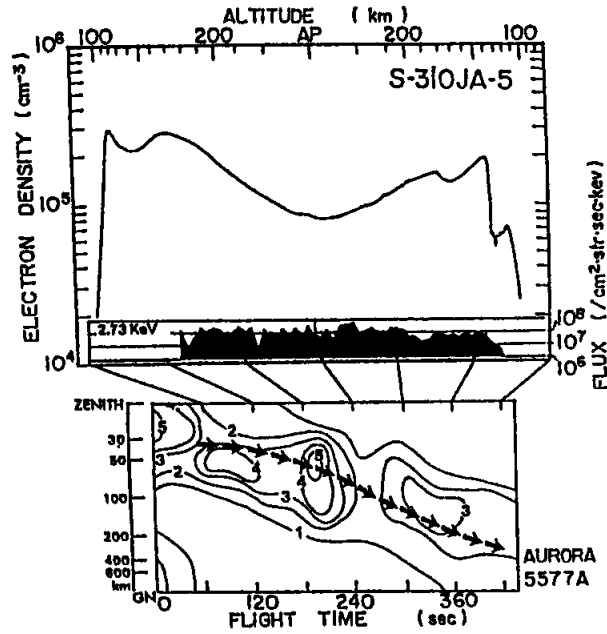

Fig. 3a. Results observed by the S-310JA-5 sounding rocket. Time variations of the electron density (after T. Takahashi and H. Oya), energetic electron flux (after H. Matsumoto and N. Kaya) are presented. Abscissa is flight time (s) or altitude (km). The upper ordinate is electron density (cm^{-3}), and the lower is energetic electron flux ($\text{cm}^{-2}\cdot\text{sr}\cdot\text{s}\cdot\text{keV}$). Aurora-diagram is aurora intensity (kR) map at 557.7 nm with the rocket trajectory obtained by projecting along the geomagnetic field line to the height of 100 km (after T. Hirasawa).

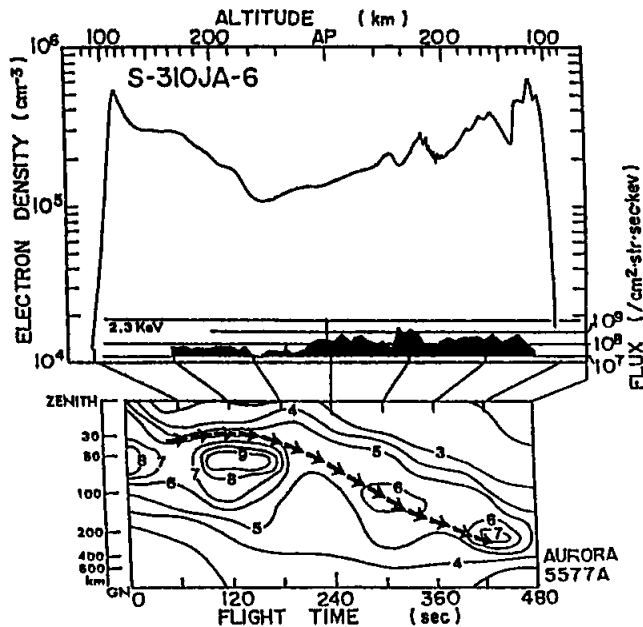

Fig. 3b. Same as Fig. 3a but for the S-310JA-6 rocket.

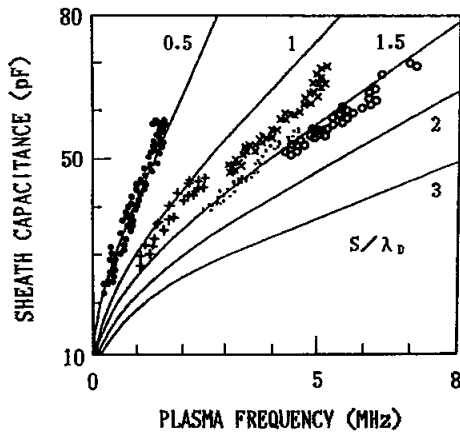

Fig. 4a.

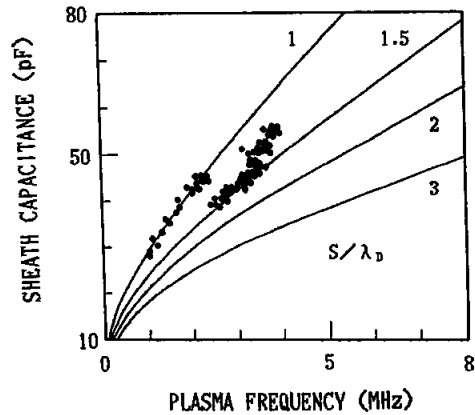

Fig. 4b.

Fig. 4a. C_s (sheath capacitance) vs. f_p (plasma frequency) diagram for S-310JA-3, 5 and 6 rockets. Parameter (S/λ_D) is the sheath thickness divided by Debye length. C_s changes with electron density along the same characteristic line with constant value of S/λ_D . Jump or shift between characteristic lines shows that probe-potential changes due to energetic electrons. Large dots (●) denote observed values obtained by S-310JA-3. Cross marks (×) denote those observed by S-310JA-6 rocket during the ascent, and circles (○) during the descent of the flight. Plus marks (+) denote those observed by S-310JA-5 in the E region during the ascent, and small dots (·) during the flight time of 136 to 335 s.

Fig. 4b. C_s - f_p diagram of S-310JA-5 rocket during descent. Data points from the apex of the flight to 335 s were again plotted.

The positive correlation between S/λ_D value and the energetic electron flux can be understood as follows. The probe potential became slightly negative when auroral electrons hit the probe surface. This made the ion sheath around the probe expanded. Accordingly the sheath capacitance of the probe was reduced.

Figure 5 summarizes the relationship between the sheath thickness and the energetic electron flux. The ordinate is energetic electron flux obtained from Fig. 3a and Fig. 3b. The abscissa is the sheath thickness normalized by λ_D . Thin-line squares denote possible ranges of the electron flux and S/λ_D obtained by S-310JA-5 in the flight time of 136–335 s and 335–390 s. Bold-line squares denote those obtained by S-310JA-6 during ascent and descent of the flight. It is clear from Fig. 5 that sheath thickness increased with auroral energetic electron flux precipitated from the magnetosphere during the geomagnetic disturbance.

3. Conclusion

A detailed study of the impedance characteristics of the impedance-probe measurement conducted in Antarctica reveals that the charging of the electrode occurred due to energetic electron precipitation from the magnetosphere. The sheath thickness normalized by the Debye length (S/λ_D) increased with the increase of energetic electron flux as well as the increase of auroral intensity at 557.7 nm observed by the meridian-scanning photometer.

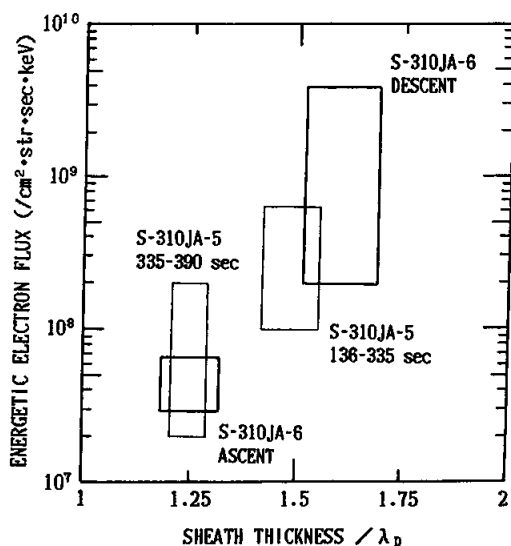

Fig. 5. Energetic electron flux versus sheath thickness normalized by the Debye length. Ordinate is energetic electron flux. Abscissa is sheath thickness normalized by the Debye length. Thin-line squares denote possible ranges of the electron flux and S/λ_D obtained by S-310JA-5 rocket in the flight time of 136–335 s and 335–390 s. Bold-line squares denote those obtained by S-310JA-6 rocket during ascent and descent of the flight. It is evident that the sheath thickness increases due to energetic electrons precipitating from the magnetosphere.

Acknowledgments

Antarctic rocket experiments at Syowa Station were carried out by the efforts of the Japanese Antarctic Research Expedition. The author would like to thank Dr. T. Takahashi of Gunma University, who kindly provided the raw data obtained with the impedance-probe. The impedance-probe was manufactured by the Meisei Electric Company. The author thanks anonymous referees for their kind suggestions in reviewing the paper.

The editor thanks Dr. Kohichiro Oyama and another referee for their help in evaluating this paper.

References

- Hirasawa, T. (1980): Polar disturbance during the flight times of the sounding rockets, S-310JA-4, 5, 6 and 7. Third Symposium on Coordinated Observations of the Ionosphere and the Magnetosphere in the Polar Region. Tokyo, Natl Inst. Polar Res., 23 (in Japanese).
- Matsumoto, H. and Kaya, N. (1980): Observations of the energetic electrons in keV range by the sounding rockets, S-310JA-5 and 6. Third Symposium on Coordinated Observations of the Ionosphere and the Magnetosphere in the Polar Region. Tokyo, Natl Inst. Polar Res., 33 (in Japanese).
- Oya, H. (1965): Effect of resonances on the admittance of an RF plasma probe surrounded by an ion sheath. Rep. Ionos. Space Res. Jpn., **19**, 243–271.
- Oya, H. and Obayashi, T. (1966): Measurements of ionospheric electron density by gyro-plasma probe.

- Space Res., 7, 480.
- Takahashi, T. and Oya, H. (1979): Measurements of electron density in the polar ionosphere. *Nankyoku Shiryô (Antarct. Rec.)*, **65**, 28–35 (in Japanese with English abstract).
- Watanabe, Y. (1996): Various frequency spectra of the impedance probe with electron beam experiment installed on the S-310-24. Proceeding at the 100th meeting of SGEPS (Japanese abstract).
- Watanabe, Y. (1998): 4 phenomena detected on the frequency spectra of the impedance probe in the space plasma with electron beam from the rocket. The 32nd Nagoya COSPAR (English abstract).

(Received September 22, 1999; Revised manuscript accepted January 26, 2000)